

E940

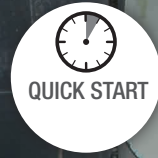

MACHINE TOOL APPLICATIONS

Laser measurement and alignment system for machine tools



TOTAL CONTROL

QUALITY AND PRECISION

In order to meet quality requirements and minimise waste, the checking and alignment of machine tools is essential. The most important thing to check is the geometry of the machine; not even a precisely calibrated linear motion can compensate for a crooked movement or uneven surface. The correct machine geometry is the basis for being able to produce parts that remain within the tolerances.

The Easy-Laser® E940 Machine tool system can handle most tasks in this field, despite the fact that there is considerable variation as regards to machine design: boring machines, vertical, horizontal and portal milling machines, lathes, vertical lathes, drilling machines, automatic drills, water cutting machines, presses, etc.

All measurements will compare results with ISO10791-1 or 10791-2, which are the standard used for machine tool measurement. Compared to conventional methods, such as dial gauges, etc work can be carried out much more accurate with the use of a laser measurement system. And do not forget, the results can be documented.

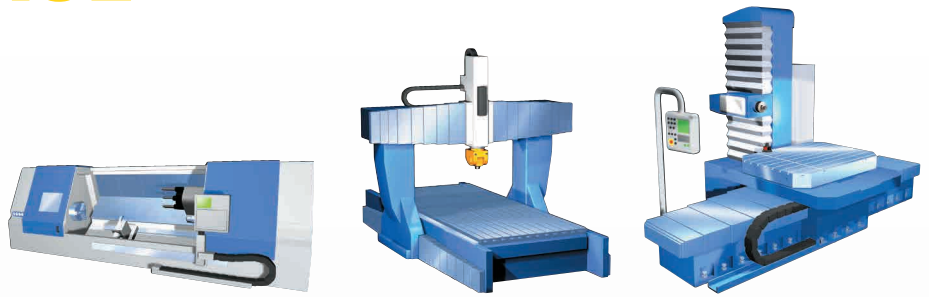

LASER MEASUREMENT SYSTEM BENEFITS:

- Light and easy-to-use equipment = shorter time for preparations and measurements
- Possible to measure and align at long distances = greater accuracy
- Possible to measure both X and Y (Z) directions at the same time = saves time
- The reference (laser beam) is always 100% straight
- Possible to document the measurement results as PDF and transfer to a PC

WHAT YOU CAN CHECK WITH THE EASY-LASER® E940 MACHINE TOOL SYSTEM:

- Straightness of machine axes
- Spindle direction
- Spindle to spindle/tail stock
- Squareness between machine axes
- Flatness on machine table or machine bed
- Bearing play check
- Bearing condition measured in g's

SPECIAL FEATURE OF THE EASY-LASER® E940 MACHINE TOOL SYSTEM:

- HyperPSD™ technology: makes it possible to display a resolution of 0.0001 mm [0.000005"/0.005 mils].



SPINDLE DIRECTION

When measuring spindle direction, place the laser transmitter in the machine spindle centre and the detector on the section that can be moved along with the machine's working area. Record the first measurement value at the first measurement point, then rotate the spindle 180° and record the next value. Then move the detector to the second measurement point and repeat the procedure. You can use either the D22 or the ESH-unit as laser transmitter. (See *Parts* pages for more information.)

- A. Measuring view. Detector surface/Target.
 B. Result view. Colour coded. Red=out of tolerance.

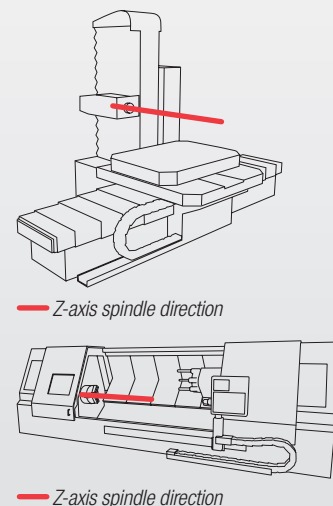
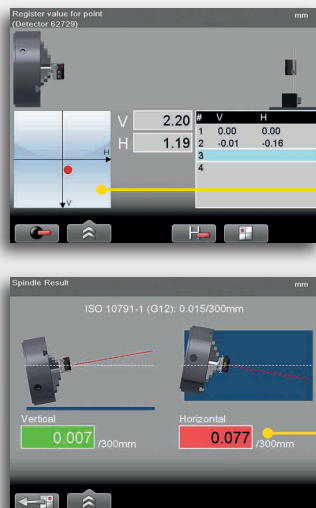

SPINDLE TO SPINDLE

Another application is alignment of the secondary spindle with the main spindle. Both measuring units, EMH and ESH, are used in this case.

- A. Input view.

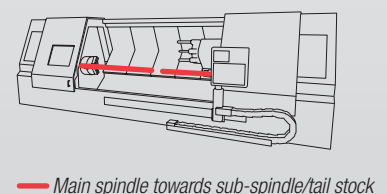
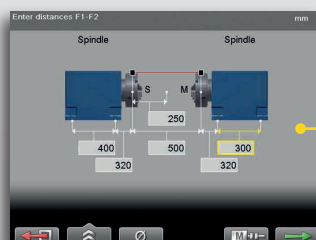

SQUARENESS

When measuring squareness, first record two measurement values on a single object to create a reference for the angle. Then use the built-in angular prism in laser transmitter D22, which deflects the laser beam 90°, and record two new measurement values on the second object. The measurement values are converted into an angular value, showing any deviation from 90° in the second object.

A. Measuring view.

B. Result view. Green=inside tolerance. Use the standard tolerances, or set your own.

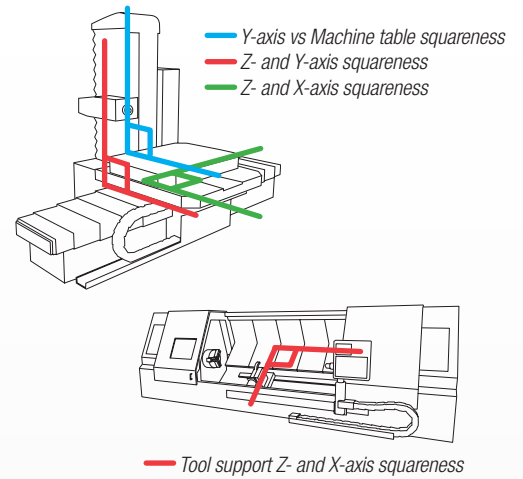
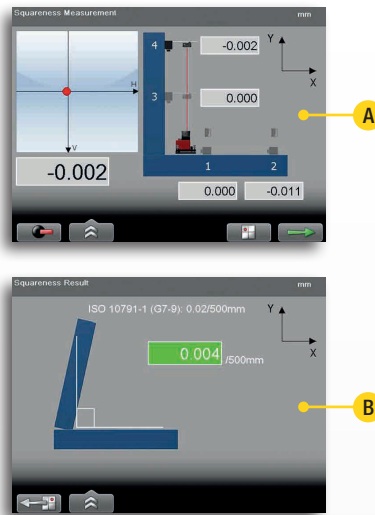

STRAIGHTNESS

Measuring straightness, like all other geometry measurements, relies on the use of the laser beam as a reference. A great advantage is that you can measure the horizontal and vertical direction at the same time. You position the detector at selected measurement points and record the values. After measuring, set two suitable measurement points as references (0), then convert the remaining points to this new reference line. New measurement points can be added to or removed from the existing set.

A. Result view, graph.

B. Result view, table.

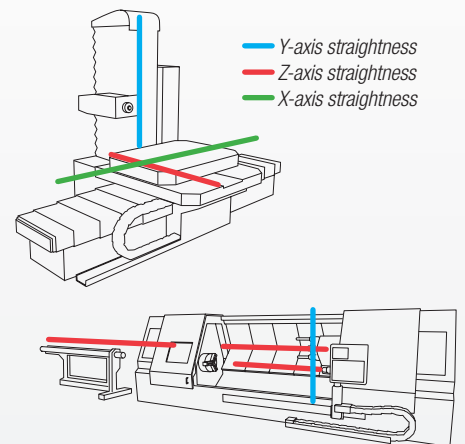
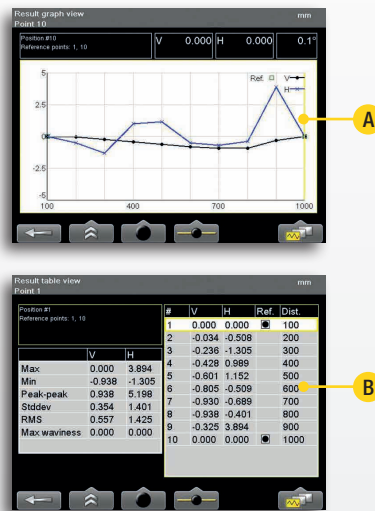

FLATNESS

Flatness can be measured on a rectangular or circular plane. The user can select a method according to the type of measurement required. Position the detector at selected measurement points and record the values. After measuring, set three of the measurement points as references (0), then the remaining points are recalculated to the new reference plane formed.

A. Measuring view. Point to measure is marked with yellow. Reference (zero) point marked with box.

B. Result view, 3D graph. Can be rotated and angled for better visibility.

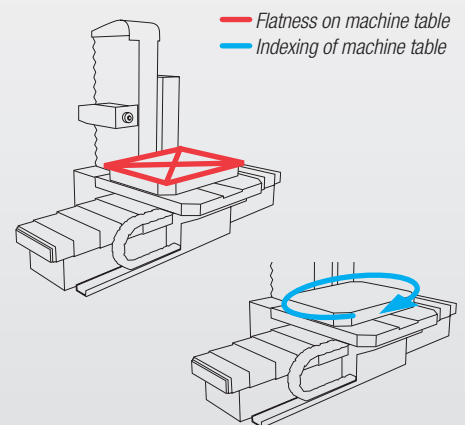
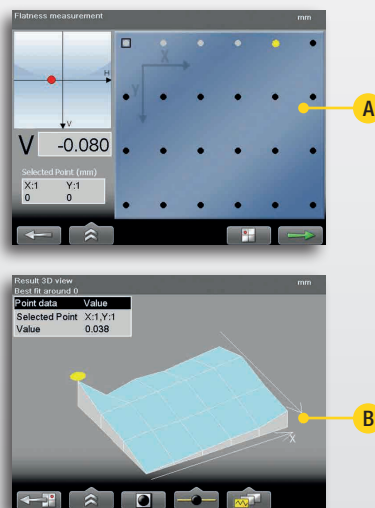

LEVEL

Before any measurements are performed, an important first step is to level the machine. For this type of alignment, the laser transmitter is placed beside the machine on a tripod or similar. Then adjust the machine with live values to the correct position, with spirit level as the reference.

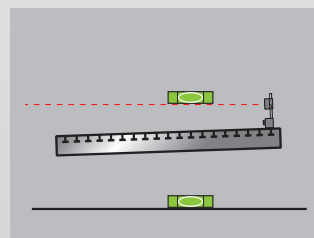

As a complement the Digital Precision Level E290 (accessory) can be used for leveling.

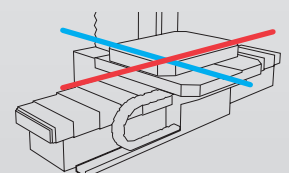

THE PARTS OF THE SYSTEM

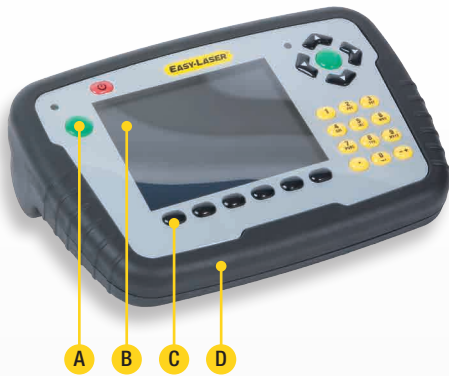

- A. Two Enter buttons, for left and right-handed users
- B. Large 5.7", easy to read colour display
- C. Proper buttons for clear feedback
- D. Thin profile gives a perfect grip for your hands

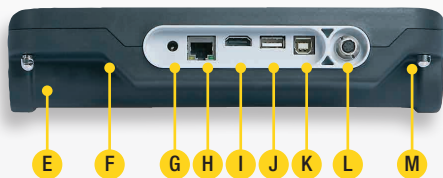

- E. Battery compartment
 - F. Robust, rubber coated design
 - G. Connection for charger
 - H. Network connection
 - I. Expansion port
 - J. USB A
 - K. USB B
 - L. Easy-Laser® measurement equipment
 - M. Mounting for shoulder strap
- Note: Dust and splash guards for connectors removed on picture.

DISPLAY UNIT

The display unit enables you to work more efficiently and for longer than ever before. It has Bluetooth® wireless technology and integrated rechargeable battery.

NEVER LOSE POWER!

The display unit is equipped with our Endurio™ Power management system. This ensures that you never have to stop in the middle of a measurement because the battery has run out.



PERSONAL SETTINGS

You can create a user profile where you can save your personal settings. You can also have different settings for different types of measurements.

LANGUAGE SELECTION

You can choose the language you want to appear on the screen: English, Spanish, German, French, Portuguese, Chinese, Japanese, Korean, Italian, Dutch, Russian, Polish, Finnish and Swedish are available. More languages to follow.

ERGONOMIC

The display unit has a thin, easy-to-grip and rubber coated profile that ensures a secure grip. It has large well-spaced buttons that give clear feedback when pushed. In addition, the two Enter buttons make the system suitable for both right and left-handed users. The display screen has clear graphics that guide you through the measurement process.

UPGRADING

If you wish to expand functionality in the future, the software in the display unit can be upgraded via the internet or by connecting a USB memory containing the new software.

HYPER PSD SUPPORT

The display unit software in system E940 has support for HyperPSD™ high resolution units. See next page for more information.

DOCUMENTATION

SAVE TO USB MEMORY

You can easily save desired measurements on your USB memory. This enables you to take it to your computer to print reports whilst leaving the measurement system in place to continue measuring.

SAVING IN THE BUILT-IN MEMORY

You can, of course, save all measurements in the display unit's internal memory. You can then open an old measurement and remeasure those points you adjusted.

CONNECT TO PRINTER

Connect a thermal printer (accessory) and print locally. Good for example when you want to see the values before and after adjustment, or want to leave a documentation of the measurement on site.

CONNECT TO YOUR COMPUTER

The display unit is connected to the computer via the USB port. It then appears on the desktop as a "Mass Storage Device" which you can easily transfer files to and from.

CREATE A PDF REPORT DIRECTLY

When measurement is complete it is possible to generate a PDF report containing graphs and measurement data directly in the measurement system's display unit. All the information about the measurement object is documented, and you can add your company's logo and address details if you so wish.

EASYLINK™ PC SOFTWARE

With the EasyLink™ database program you can save and organise all your measurements in one place, produce reports with both data and images and export to your maintenance systems. You can customise what your Excel reports should look like and what data should be visible and where it should be positioned. The program has a clear folder structure, where you drag and drop files from the display unit to the database. Create your own structure with folders for manufacturer, department or machine type for example. The database can also be located on a common server and shared with other users. For extra safety you can use EasyLink™ to make backups of what you have saved in the display unit.



LASER TRANSMITTER D22

Laser transmitter D22 can be used to measure flatness, straightness, squareness, level and parallelism. The laser beam can sweep 360° with a measurement distance of up to 40 metres [130'] in radius. The laser beam can be angled 90° to the sweep, within 0.01 mm/m [0.05 mils/INCH].

The transmitter has many mounting options. Attach it with the three magnetic feet, horizontally or vertically. Attach it with a pin in the spindle. Or put it beside the machine for example a tripod (optional).

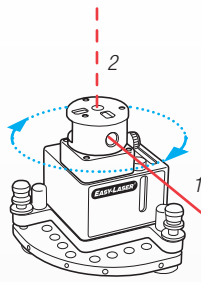

- 1: The laser beam is used for a 360° sweep.
- 2: The laser beam is angled at 90° to the sweep.
- 3: Machine spindle pin; Center attachment.
- 4: Machine spindle pin; Edge attachment.



- A. Laser aperture
- B. Swivelling head
- C. Laser aperture
- D. Leveling screws (x2)
- E. Magnetic feet (x3)

MEASURING UNITS (ESH/EMH)

Laser diode and PSD detector in one compact housing. In system E940 these units have got the HyperPSD™ technology. This makes it possible to display a resolution of 0.0001 mm [0.000005"/0.005 mils]. The units have 2-axis PSD which reads the position in two directions at the same time.

For alignment of two to each other pointing shafts both units, EMH and ESH, are used.

The EMH-unit is used as detector when measuring with a separate laser transmitters, but then without turning the laser on. Most common is to mount the unit on a magnet base (see D to the right).

The ESH-unit can act as a laser transmitter (see E), and together with the spindle bracket be used for measurement of pointing direction. The laser beam can be pointed through the clamping pin (F), making it possible to align bar feeders for example.

The Bluetooth® unit for wireless communication is compact and makes the measurement work easier than using cables, especially when rotating the units in the spindle.

The measuring units conform with IP class 66 and 67.

- A. Bluetooth® unit
- B. Laser aperture
- C. PSD
- D. Magnet base
- E. Bracket for mounting of the S-unit in a spindle
- F. S-unit turned to point laser through pin

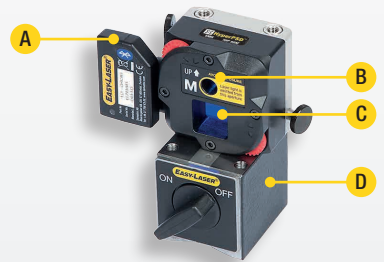

VIBROMETER PROBE E285

With the Vibrometer you check the bearing condition (g-value) of the spindle bearing. (See photo on last page.)



EXPANDABILITY / ACCESSORIES



A. OLED Display
B. Mounting holes (x2)
C. Precision prismatic base of hardened steel

DIGITAL PRECISION LEVEL E290

For installation, setting up and maintenance of precision machines, leveling of machine tables, rolls, etc – basically anything you can think of! Built-in rechargeable battery. OLED display with digital and graphical representation of angles. Connects wireless to display unit E51 for more functionality. Resolution 0.01 mm/m (0.001°). Measurement range ± 2 mm/m. WxHxD: 149x40x35 mm [5.9x1.6x1.4"]
Part No. 12-0846
Part No. 12-0857 (kit with charger)



Clear OLED display for ease-of-use. The angle can be displayed as mm/m, mils/inch, inch/foot, degrees and arcsec.



A. Clamping pin
B. Laser aperture

LASER TRANSMITTER D146

For measuring spindle direction and straightness. Clamping pin $\varnothing 20$ mm. A clamping pin can also be fitted by the laser opening, for use when aligning bar feeders, for example. Measurement distance 20 metres [65']. Can be used in a rotating spindle (max. 2000rpm). Part No. 12-0146

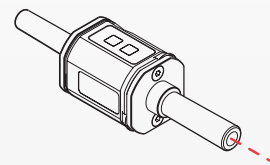

Option: An extra clamping pin can be fitted by the laser opening.

V-BRACKET WITH CHAIN



For mounting of measuring units on shafts.
Part No. 12-0016

CHARGER 12–36 V



To charge the display unit via 12–36 V socket, for example in a car. Part No. 12-0585

EXTENSION CABLES



Length 5 m [16.4'], Part No. 12-0108
Length 10 m [32.8'], Part No. 12-0180

PROTECTIVE COVER



Protective case for display unit. With shoulder strap.
Part No. 01-1379

EXTENSION RODS



Set of 8 rods 120 mm [4.72"], extendable. Part No. 12-0324

DETECTOR E9



Wireless detector $\varnothing 45$ mm, L=100 mm [$\varnothing 1.77$ ", L=3.94"]. 20 mm [0.78" sq] 2 axis PSD.
Part No. 12-0759

BATTERY PACK



Rechargeable battery pack for longer operating time.
Part No. 12-0617

PRINTER



Compact thermal printer. Connected in the USB port.
Part No. 03-1004

TECHNICAL DATA

System	
Relative humidity	10–95%
Weight (complete system)	15 kg [33 lbs]
Carrying case	WxHxD: 550x450x210 mm [21.6x17.7x8.3"] Drop tested (3 m/10 feet). Dust and water proof.

Laser transmitter D22	
Type of laser	Diode laser
Laser wavelength	635–670 nm, visible red light
Laser Safety Class	Class 2
Output	< 1 mW
Beam diameter	6 mm [1/4"] at aperture
Working area, range	40-metre radius [130']
Type of battery	1 x R14 (C)
Operating time/battery	approx. 24 hours
Operating temperature	0–50 °C
Levelling range	± 30 mm/m [± 1.7"]
3 x spirit levels' scaling	0.02 mm/m
Squareness between laser beams	0.01 mm/m [2 arc sec.]
Flatness of sweep	0.02 mm
Fine turning	0.1 mm/m [20 arc sec.]
2 x spirit levels for rotation	5 mm/m
Housing material	Aluminium
Dimensions	WxHxD: 139x169x139 mm [5.47x6.64x5.47"]
Weight	2650 g [5.8 lbs]

Measuring units EMH / ESH (HyperPSD™)	
Type of detector	2-axis PSD 20x20 mm [0.78" sq]
Resolution	0.0001 mm [0.000005"/0.005 mils]
Measuring errors	±0.5% +1 digit
Measurement range	Up to 20 m [66 feet]
Type of laser	Diode laser
Laser wavelength	635–670 nm
Laser class	Safety class II
Laser output	<1 mW
Electronic inclinometer	0, 1° resolution
Thermal sensors	± 1° C accuracy
Environmental protection	IP class 66 and 67
Temperature range	-10–50 °C
Internal battery	Li Po (2.5 Wh)
Housing material	Anodized aluminium
Dimensions	WxHxD: 60x60x42 mm [2.36"x2.36"x1.65"]
Weight	202 g [7.1 oz]

Display unit E51 with HyperPSD™ support	
Type of display/size	VGA 5.7" colour
Displayed resolution	0.0001 mm [0.000005"/0.005 mils]
Power management	Endurio™ system
Internal battery (stationary)	Li Ion (43 Wh)
Battery compartment	For 4 pcs R 14 (C)
Operating time	Appr. 30 hours (Normal operating cycle)
Operating temperature	-10–50 °C
Connections	USB A, USB B, External, Easy-Laser® units, Network
Wireless communication	Class I Bluetooth® Wireless Technology
Storage memory	>100,000 measurements
Help functions	Calculator, Unit converter
Environmental protection	IP Class 65
Housing material	PC/ABS + TPE
Dimensions	WxHxD: 250x175x63 [9.8x6.9x2.5"]
Weight (without batteries)	1030 g [2.3 lbs]

Vibrometer E285	
Probe sensitivity	100 mV/g ±10%
Dimensions	Magnet: L=20 mm [4/5"], Ø=15 mm [19/32"] Gauge tip: L=65 mm [2 1/2"]

Bluetooth® wireless units	
Wireless communication	Class I Bluetooth® Wireless Technology
Operating temperature	-10–50 °C
Environmental protection	IP Class 66 and 67
Housing material	ABS
Dimensions	53x32x24 mm [2.1x1.2x0.9"]
Weight	25 g [0.9 oz]

Magnet bases	
Holding power	800 N

Spindle bracket for measuring unit	
Clamping pin	Ø 20 mm, L= 40 mm [Ø 0.78", L=1.57"]

Rods (extendable)	
Length	4x60, 8x120 mm [4x2.36", 8x4.72"]

Cables	
Type	With Push/Pull connectors
System cable	Length 2 m [78.7"]
Extension system cable	Length 5 m [196.8"]
USB cable	Length 1.8 m [70.8"]

EasyLink™ Data base software	
System requirements	Windows® XP, Vista, 7, 8. For the export functions, Excel 2003 or newer must be installed on the PC.

A complete system contains

- 1 Display unit E51 (With HyperPSD™ support)
- 1 Laser transmitter D22 incl. tilt table
- 1 Measuring unit ESH (HyperPSD™)
- 1 Measuring unit EMH (HyperPSD™)
- 2 Bluetooth® unit
- 1 E285 Vibrometer probe
- 2 Cable 2 m
- 2 Cable 5 m, extension
- 1 Machine spindle pin for D22
- 2 Spindle bracket for measuring unit
- 1 Magnet base
- 1 Magnet base with turnable head
- 2 Offset bracket
- 1 Rods (8x120 mm)
- 1 Set of Rods 4x60 mm
- 1 Safety strap for laser transmitter
- 1 Manual
- 1 Machine Tools Guide
- 1 Measuring tape 5 m
- 1 USB memory stick with EasyLink™ PC software
- 1 USB cable
- 1 Battery charger (100–240 V AC)
- 1 Hexagon wrench set
- 1 Shoulder strap for Display unit
- 1 Cleaning cloth for optics
- 1 CD with documentation
- 1 Carrying case

System Easy-Laser® E940 Machine tool, Part No. 12-0761



Note: For the US market some measurement programs have limited functionality when used together with 2-axis units.

EASY-LASER® E940

LONG WARRANTY PERIOD

The Easy-Laser® systems are developed with the backing of more than 25 years' experience of solving measurement and alignment problems for the industry, all over the world. The systems come with a generous three year warranty*. The manufacturing and quality systems are approved according to ISO9001.



QUICK SERVICE

Our service department usually takes care of servicing or calibration within five working days. All this makes Easy-Laser® a safer working partner for your operation. As an extra service, we provide a 48 hour express service for when accidents occur and time is of the essence. Contact us for further information about terms and conditions.



CLEVER DESIGN

Our development department continuously strives to simplify the user's work through innovative and clever solutions. It is the collaboration between laser transmitter, detector and software that is the key to a quick and easy measurement. This is where Easy-Laser® shines.



**THE TOTAL
ALIGNMENT
SOLUTION**

EXPANDABLE / ADAPTABLE

In addition to our already versatile standard system we can also offer a wide range of accessories. This means that you can adapt the measurement system to your needs, now and in the future. That is cost effective!

PICTURES TO THE RIGHT

- A. Bar feeder
- B. ESH-unit mounted for bar feeder alignment
- C. Squareness measurement with D22 and EMH-unit
- D. Flatness measurement of machine table
- E. Vibration measurement (bearing condition)

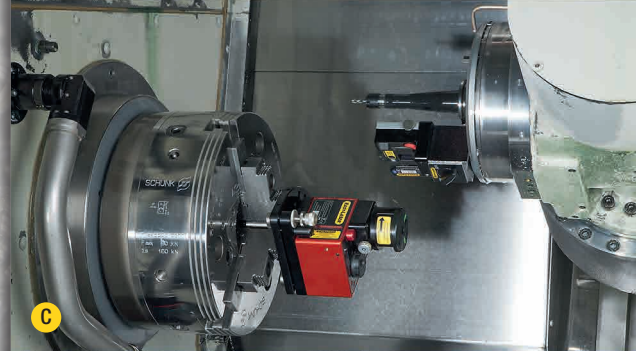
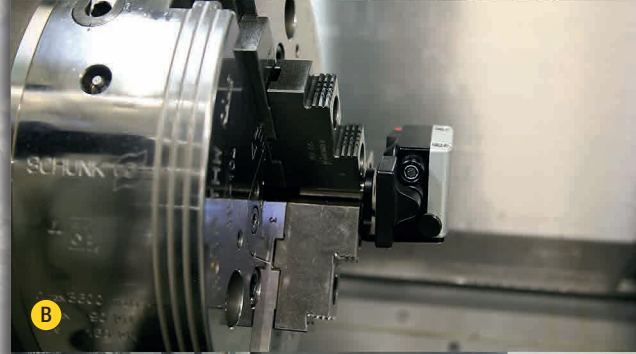

* Extend the warranty from 2 to 3 years by registering your system on the Internet.

Easy-Laser® is manufactured by Damalini AB, Alfagatan 6, SE-431 49 Mölndal, Sweden
Tel +46 (0)31 708 63 00, Fax +46 (0)31 708 63 50, e-mail: info@damalini.se, www.damalini.com
© 2014 Damalini AB. We reserve the right to make changes without prior notification.
Easy-Laser® is a registered trademark of Damalini AB. Other trademarks belong to the relevant copyright holder. This product corresponds to: EN60825-1, 21 CFR 1040.10 and 1040.11
This device contains FCC ID: PVH0925, IC: 5325A-0925.



ISO9001
CERTIFIED

05-0682 Rev3



J.L. Griffin LLC.
4625-B Turtle Creek Drive,
Brookfield, WI 53005
TEL 414.218.8088
E-mail jim@jgriffin.com