

E710



EXPANDABLE



QUICK START



40° MIN.
ROTATION



BARCODE
ENTERING

 Bluetooth®



THE TOTAL
ALIGNMENT
SOLUTION



SHAFT ALIGNMENT

Professional measurement and alignment system for rotating machines

EASY-LASER®



A PRECISION CHOICE

is also a safe choice!

LONG EXPERIENCE

Easy-Laser® measurement systems have been developed from more than twenty five years experience of solving measurement problems for the industry. This is long enough to understand problems out in the real world. At the same time, we are young enough to see opportunities and solutions with fresh eyes. Our development department consists of designers who specialise in mechanics, electronics, optics and programming. Taking full control from the initial idea to the finished product and working closely with our users, we are able to create user-friendly measurement systems.

LONG TERM AND RELIABLE

Our philosophy is that the products we develop must not only have long operating times but also a long lifecycle. We design our products to be robust, with as few small parts as possible. The Easy-Laser® measuring systems can therefore withstand rough handling and work with the greatest precision in the most demanding environments, year after year. Easy-Laser® is a dependable and safe choice from every point of view.

FAST SERVICE AND SUPPORT

Easy-Laser® measurement systems are available from local dealers in more than 70 countries, but there are users to be found in many more countries. For them, professional tools and the best possible support are of great importance, and the same is no doubt true for you as well. Service and repair centres can be found all over the world for your convenience. You can be assured that we will provide you with the fastest and best possible support. Our service department usually takes care of servicing or calibration within five working days. As an extra service, we provide a 48-hour express service for when accidents occur and time is of the essence. Contact us for further information about terms and conditions.

LARGE SAVINGS

Easy-Laser® measurement systems are already extremely flexible in their standard form. By using clever accessories, you can adapt the systems for your own needs, now and in the future as your measurement requirements change. It is cost-effective. Your production capacity increases by being able

to measure faster and with greater reliability. Easy-Laser® helps you remedy production errors quickly and easily. This can save you large amounts of money, and your investment can even be repaid within a few months.

A MEASURING SYSTEM FOR ALL STAGES OF MACHINE SET-UP

With Easy-Laser® E710 the same system is used to reassure yourself that the machines have optimal conditions for problem-free operation, without risk of unplanned downtime etc. Carry out the following:

- Check the base
- Check vibration level
- Check bearing play
- Check soft foot
- Measure the machine
- Align the machine
- Document the results



**THE TOTAL
ALIGNMENT
SOLUTION**

HIGHLIGHTS

- The measurement system for all stages of machine set-up.
- Easy to learn, easy to use.
- 3 year warranty gives assurance.
- Fast service and support. 48-hours Express service if necessary.
- Ergonomic design.
- Low overall costs during the entire lifecycle of the product, for example servicing, accessories, etc.
- Endurio™ Power management system ensures that you never have to stop in the middle of a measurement because the battery has run out.
- Expandable / Adaptable
A range of accessories means that you can adapt the measurement system to your needs, now and in the future.

SIMPLE AND EFFECTIVE

Easy to use = Fast and efficient!



BARCODE READER



The barcode reader is used to enter the machine data before measurement is taken. After the first measurement is recorded, the adhesive barcode label is applied to the machine. Next time the machine is checked, the measurements, compensation values and tolerances can be read directly from the barcode. Simple and accurate!

Measurement and alignment should be easy! That is the fundamental philosophy behind our measurement systems. When we talk about simplicity we mean several things, for example, simple to place or mount the measurement equipment on the measurement object, easy to perform the measurement and easy to interpret the measurement result. Simple to use = quick and easy!



Easy-Laser® is used to align generators and gearboxes in wind turbines of a number of sizes and makes. Special brackets are available (accessories) for alignment with locked rotors, which increases the safety for the operator.

Engines, gearboxes and propeller shafts on ships are aligned using Easy-Laser® system. Thanks to flexible brackets you can install the equipment in the most appropriate place; shaft, coupling or flywheel.

Easy-Laser® is used to align pumps and motors for all types of industries and installations. Correctly set-up and aligned machines are a requirement for achieving optimum service life and minimal energy consumption.

SHAFT ALIGNMENT

HORIZONTAL MACHINES



Horizontally coupled machines often consist of a pump and motor, but there can also be other types of machine such as gearboxes and compressors. Regardless of what the machine is it is easy to measure and align with Easy-Laser®. The measuring units (M and S) are mounted on each side of the coupling with cable or wireless communication to the display unit. Then follow the step-by-step instructions on screen (see below).



In the Horizontal and Machine train programs, you can choose which machines are to be shown, which side they are on, and specify the number of pairs of feet to correspond with your reality. You can even name the machines individually.

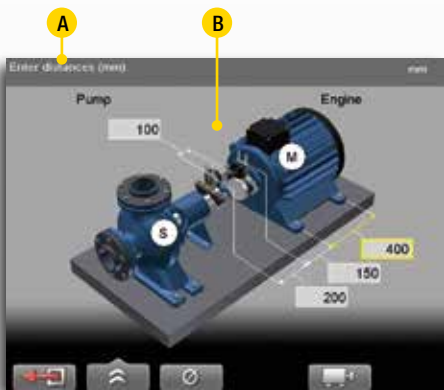
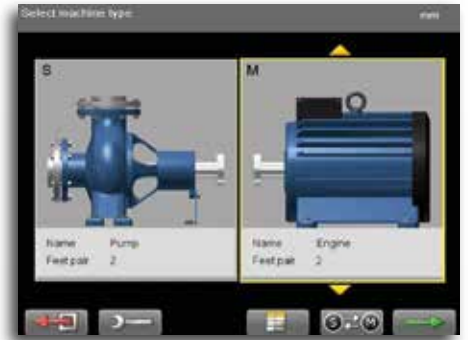

1. Enter the distances between measuring units and the machine feet. If you enter the coupling diameter you can also get the result as gap/sag.

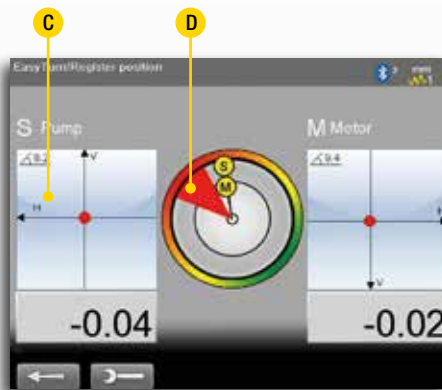

2. Take the measurement values in three positions with as little as 20° between. It is clearly visible on the display when the laser beam hits the detector.

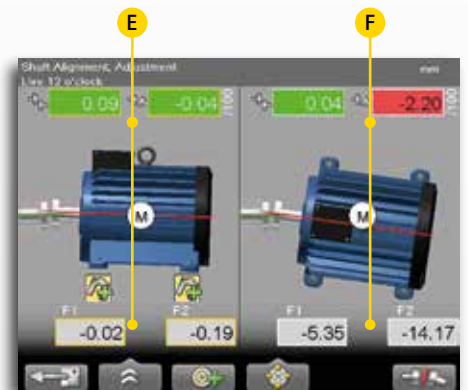

3. The live values are used to adjust the machine. For clarity the adjustment is displayed both graphically and numerically. Horizontal and Vertical directions are shown at the same time.

A. Information field. States what you must do at each stage of the measurement. Also displays Bluetooth® connection, warning symbols etc.

B. You can start from a previous measurement and so avoid re-entering the dimensions, the barcode reader is the fastest method.

C. The detector surface is shown on the screen and functions as an electronic target for the laser beams.

D. 20° marking. The S unit position on the shaft is shown. You can also choose to show the M unit when you align uncoupled machines.

E. Shims values for front and rear pairs of feet. Offset and angular values are colour coded in order to determine the result more quickly: red=outside tolerance, green=inside tolerance.

F. Horizontal adjustment values. Offset and angular values are colour coded.

SOFT FOOT CHECK



Start the alignment work by performing a soft foot check to ensure the machine is resting evenly on all its feet. This is necessary for a reliable alignment. The program shows which foot (feet) should be corrected. After the soft foot check you can go directly to the alignment program with all of the machine's distances saved.

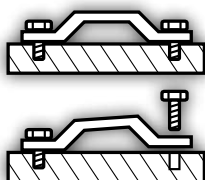

EASYTURN™ AND MULTIPOINT



With the EasyTurn™ function you can start measurement anywhere on the turn. Turn the shafts with the measuring units to three positions in any direction with as little as 20° between to register the measurement value. Measurement is complete! For advanced applications, such as turbines, there is a Multipoint function where any number of measuring points around the whole or part of the rotation can be registered.

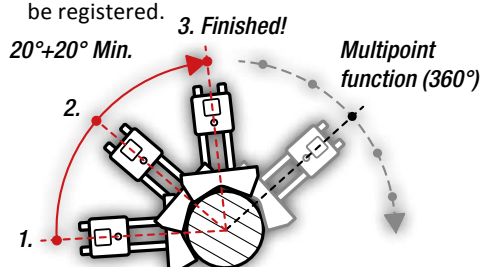

THERMAL GROWTH COMPENSATION



In many cases, the machines (for example a pump and motor) expand considerably from a cold to a hot state (operating temperature). The Thermal Growth Compensation function allows the measurement system to calculate the correct shims and adjustment values even in such cases. The compensation values for the machines are normally supplied by the manufacturers.

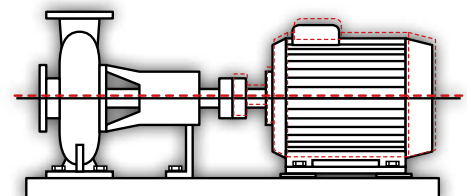



VERTICAL/FLANGE-MOUNTED MACHINES



Alignment of vertical and flange-mounted machines. Shows centre offset, angular error and shim value at each bolt.



CARDAN/OFFSET-MOUNTED MACHINES



Alignment of cardan/offset mounted machines. (Accessory Cardan fixture, Part No. 12-0615 is required.)



MACHINE TRAINS



Regardless of what machines you have and in which order they were assembled, you can build your own machine train with theoretically as many machines as you like. You can pick the reference machine manually, or let the program choose one that will minimize the need for adjustments.

TOLERANCE CHECK



Measurement results can be checked against pre-defined tolerance tables or values you determine yourself. In this way, you can see immediately whether the alignment is within the approved tolerances. This means the times for alignment are shortened considerably.

LIVE-ANY-ANGLE 360°



This function allows adjustment of the machines live with the measuring units positioned anywhere around the shaft. Good for when machine parts prevent normal adjuster positioning.

REFERENCE FOOT LOCKING



This function allows you to lock any pair of feet on the machine. This gives great freedom when aligning base-bound or bolt-bound machines.

THREE PAIRS OF FEET / PAIR OF FEET IN FRONT



The software can handle machine design of all types: two pairs of feet, three pairs of feet, pair of feet before the coupling etc.

QUALITY ASSESSMENT



Function in Multipoint measurement that helps you achieve the best possible result during alignment.

MEASUREMENT VALUE FILTER



Advanced electronic filter function that can be used for a reliable measurement result even in a very poor measurement environment, for example where there is air turbulence from open entrances or vibrations from adjacent machines.

SWAP VIEW FUNCTION



Choose from which side you want to display the machine, so it corresponds to your reality. Simplifies the understanding of the adjustment directions.

MANY OPTIONS

SHEAVE/PULLEY ALIGNMENT



Using the system you can align sheaves and pulleys with digital precision. Adjustment of the machines is displayed in real time on the screen, with readings for angle and axial displacement in both the vertical and horizontal axes, as well as an adjustment value for the front or rear foot pair. The result can be documented as normal. (Requires the E180 BTA accessory.)

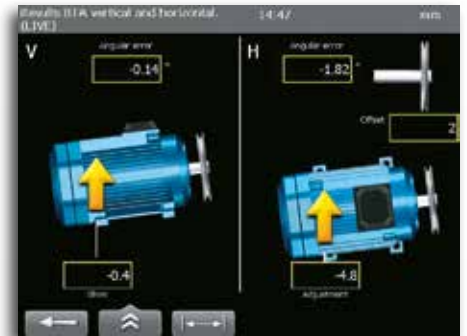
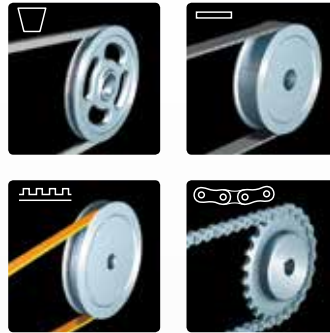

VIBRATION MEASUREMENT AND BEARING CONDITION



You can measure vibration levels (mm/s, inch/s) and bearing condition (g-value). The program guides the user through the points to measure on the machine: vertical, horizontal and axial. The result can be documented. (Requires the E285 Vibrometer probe accessory.)



STRAIGHTNESS MEASUREMENT



With our program for measuring straightness, you can easily measure long shafts, rolls, bearings, bases, machine structures etc. All you have to do is define a number of measuring points, in advance or while measuring. You will be able to get the result for both the horizontal and vertical alignment, graphically as well as digitally. To get even more out of your system, add the D22 swiveling laser.

TWIST AND FLATNESS MEASUREMENT



The twist measurement program allows you to check the flatness or twist of the machine foundation using only the measuring units in the system. A flatness program is also included, for checking larger surfaces.

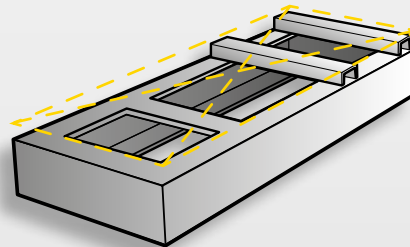

CHECKING BEARING PLAY



All our measurement systems come with the extremely useful Values program. The program can be used e.g. when one wants to measure as with dial gauges and to check bearing play. With the standard equipment and completely normal set up on the machine!

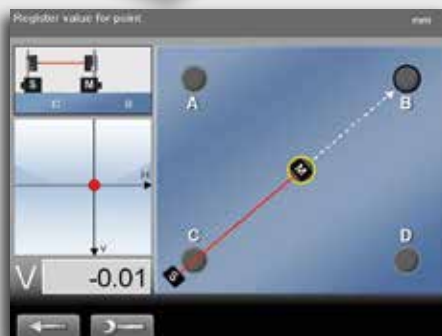
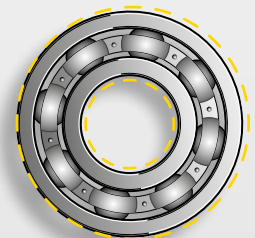

OFFSET AND ANGLE



This program shows centre offset and angular error between two shafts, for example. The values are displayed for both horizontal and vertical direction simultaneously. Can also be used for dynamic measurements.

DOCUMENTATION



CREATE A PDF REPORT DIRECTLY

When measurement is complete it is possible to generate a PDF report containing graphs and measurement data directly in the measurement system's display unit. All the information about the measurement object is documented, and you can add your company's logo and address details if you so wish.

SAVING IN THE BUILT-IN MEMORY

You can, of course, save all measurements in the display unit's internal memory.

SAVE TO USB MEMORY

You can easily save desired measurements on your USB memory. This enables you to take it to your computer to print reports whilst leaving the measurement system in place.

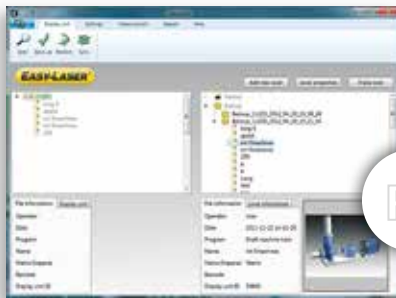

CONNECT TO YOUR COMPUTER

The display unit is connected to the computer via the USB port. It then appears on the desktop as a USB Mass Storage Device which you can easily transfer files to and from.

EASYLINK™ PC SOFTWARE

With the EasyLink™ database program you can save and organise all your measurements in one place, produce reports with both data and images and export to your maintenance systems. You can customise what your Excel reports should look like and what data should be visible and where it should be positioned.

The program has a clear folder structure, where you drag and drop files from the display unit to the database. Create your own structure with folders for manufacturer, department or machine type for example. The database can also be located on a common server and shared with other users. For extra safety you can use EasyLink™ to make backups of what you have saved in the display unit.

MAJOR BENEFITS OF ALIGNMENT

You have much to gain in both time and money through having your machines aligned to the correct tolerances. An investment in a laser based alignment system such as Easy-Laser® rapidly pays for itself through lower costs for replacement parts, less downtime and smaller electricity bills. Correctly aligned machines reduce the risk of expensive breakdowns and downtime. The benefits of alignment are many:

- Increased availability and productivity of the machine = *assured production*
- Increased life of bearings and seals = *less use of replacement parts*
- Complete seals = *less leakage and better working environment*
- Optimally utilised lubricant = *less risk of overheating and secondary damage*
- Less lubricant leakage = *less lubricant consumption*
- Reduced friction = *lower energy consumption*
- Less vibration = *reduced noise level*
- Less risk of serious breakdowns = *safer working environment*

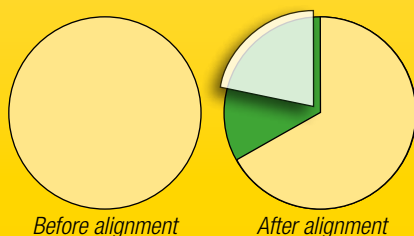

- Maintenance costs and operation per annum
- Saving after alignment per annum*
- Cost of investing in Easy-Laser®

ADVANTAGES OF LASERS

There are many advantages to aligning using lasers compared to more traditional methods such as using dial gauges:

- Easy to learn and to use
- Stable brackets without play and slack
- Much faster to mount
- Automatically calculated shims/adjustment values
- Simple tolerance check
- Simple compensation for thermal expansion
- No risk of read off errors
- Possible to document the result

Other old methods such as rulers and feeler gauges are not sufficiently accurate for today's modern machines. With a laser based alignment system checks are easy and fast to carry out. If you choose Easy-Laser® you also have a measurement system that has many more uses in the workplace than merely aligning shafts.

*The diagram is an estimate of the savings/costs relationship and is naturally dependent on the industry.

SYSTEM PARTS

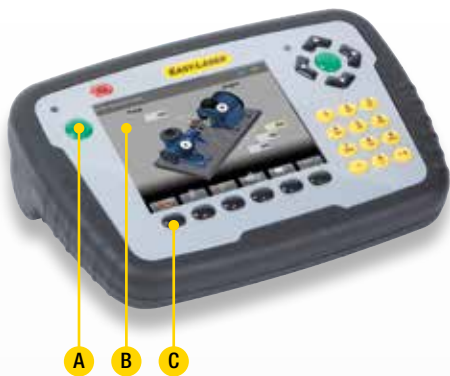

- A. Two Enter buttons, for left and right-handed users
- B. Large, easy to read 5.7" colour display
- C. Proper buttons for clear feedback



- D. Thin profile gives a perfect grip for your hands
- E. The integrated battery compartment design gives the correct angle on the display screen
- F. Battery compartment
- G. Mounting for shoulder strap

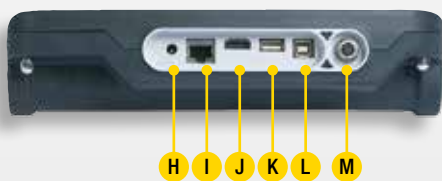

- H. Connection for charger
- I. Network connection
- J. Expansion port
- K. USB A
- L. USB B
- M. Easy-Laser® measurement equipment



- N. Dust and splash guards for connectors that are not used when measuring
- O. Robust, rubber coated design

DISPLAY UNIT

The new display unit for the E-series enables you to work more efficiently and for longer than ever before thanks to several innovative solutions. It is also ergonomically designed with easy-to-grip rubber cladding and robust construction.

NEVER LOSE POWER!

Easy-Laser® E710 is equipped with our Endurio™ Power management system. This ensures that you never have to stop in the middle of a measurement because the battery has run out. If the internal battery's charge level starts to drop, simply insert the batteries into the integrated battery compartment and continue measuring. The unique Endurio™ system also checks all the electronics so that the unit consumes as little power as possible in each position.



ERGONOMIC DESIGN

The display unit has a thin, easy-to-grip and rubber coated profile that ensures a secure grip. It has large well-spaced buttons that give clear feedback when pushed. In addition, the two Enter buttons make the system suitable for both right and left-handed users. The display screen has clear graphics that guide you through the measurement process.



Calculator

CALCULATOR

We have integrated a calculator and conversion tool for length units in the display unit.

PERSONAL SETTINGS

You can create a user profile where you can save your personal settings. You can also have different settings for different types of measurements. It makes work faster!

LANGUAGE SELECTION

You can choose the language that you want to appear on screen. English, German, French, Spanish, Portuguese, Swedish, Finnish, Russian, Polish, Dutch, Italian, Japanese, Korean and Chinese are available. More languages to follow.

UPGRADING

If you wish to expand functionality in the future, the software in the display unit can be upgraded via the internet or by connecting a USB memory containing the new software. In this way you will also have access to the measurement programmes that we develop for new purposes in the future.

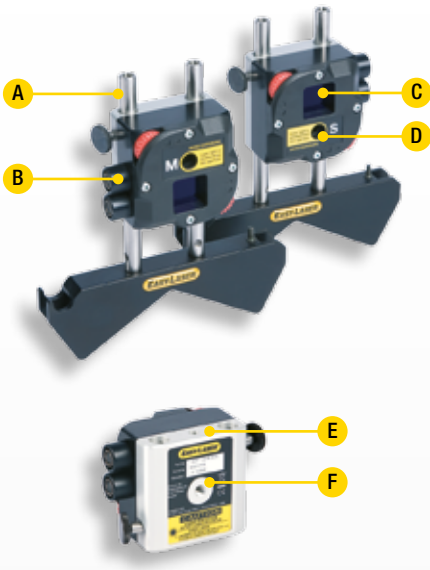

- A. The rods have a height of 60–180 mm. If necessary they can be extended "infinitely" with additional rods. Made of stainless steel.
- B. Well protected connectors
- C. PSD (2 axis)
- D. Laser aperture
- E. Stable aluminium design
- F. Threaded holes for multiple mounting options

MEASURING UNITS

The measuring units have large 20 mm [0.78" sq] detector surfaces (PSD for the greatest accuracy) which allows the possibility of measuring at a distance of up to 20 metres [66 feet]. The substantial and rigid design of aluminium and stainless steel guarantees stable measurement values and reliable alignment with the greatest precision in even the toughest of environments. The measuring units are also water and dust proof to classes IP66 and IP67. Connect to the display unit via cable or wirelessly. Both cable and wireless units are connected quickly using Push/Pull connections, no screwing required.

INCLINOMETERS IN BOTH UNITS

With electronic inclinometers in both measuring units the system knows exactly how they are positioned. This also makes it very easy to align uncoupled shafts.

ELECTRONIC TARGETS

Thanks to the two axis detectors you have access to electronic targets, that is you can see on the screen where the laser beams hit.

FLEXIBLE MOUNTING OPTIONS

The thinking behind the rigid and compact design, is that it will simplify positioning and provide varying installation methods. You can measure all types of rotating machine, large and small, equally well, regardless of shaft diameter. The units also have two extra screw holes for additional mounting options.

TWO LASERS, TWO PSD

The so called reversed measurement method with two laser beams and two PSD makes it possible to also measure very incorrectly set machines. This is particularly good for new installations, where the machines are not yet in the correct position.



WIRELESS COMMUNICATION

The unit for wireless communication is easily inserted into one of the connectors on the measuring unit. Wireless connection to the display unit enables you to work more freely. Dust and water proof to IP66 and IP67.

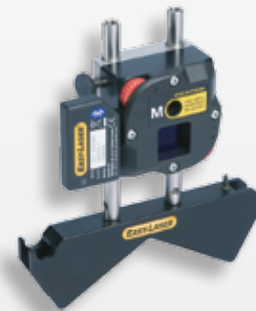

STANDARD BRACKETS INCLUDED IN THE SYSTEM



SHAFT BRACKET WITH CHAIN
For attachment around shaft or coupling. Suitable for diameters of 20–450 mm [0.8"–17.7"] with standard chains.



MAGNET BASE
For direct attachment to shaft or coupling. Very strong and stable. Three magnetic sides give flexible positioning possibilities.



OFFSET BRACKET
Allow axial displacement between measuring units in order to be able to rotate past projecting machine parts and connectors.

ACCESSORIES AND EXPANDABILITY

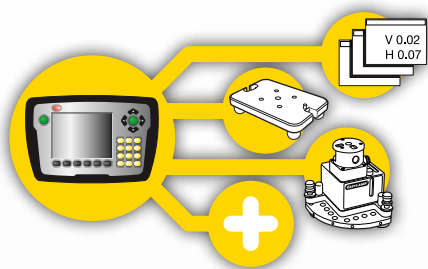

A FUTURE PROOF CHOICE

Easy-Laser® measurement systems are already extremely flexible in their standard form. By using clever accessories, you can adapt the systems for your own needs, now and in the future as your measurement requirements change. It is cost-effective. We have standardised measurements between the mounting holes in the different parts, and often there are mounting holes

on several sides to facilitate mounting on the machine. Experience tells us that this is very much appreciated. A further advantage is that you can use one of the measuring units separately as a detector with, for example, our geometric laser D22. This expands the areas of application of the measurement system. Easy-Laser® is a system that is complete in its full meaning!



MAGNETIC BRACKET



Bracket for axial mounting on flange or shaft end. With four super magnets.
Part No. 12-0413

THIN SHAFT BRACKET



This is used, for example, when there is limited space between the coupling and machine. Thin chain and lock tools included. Width: 12 mm [0.47"]. Part No. 12-0412

SLIDING BRACKET



Used when the shafts cannot be rotated. The spherical feet give a stable position against the shaft. Mounted with standard chains. Part No. 12-0039

CARDAN BRACKET



For alignment of Cardan/offset mounted machines. Part No. 12-0615

EXTENSION RODS



Screwed together. Extendable theoretically "unlimited".
Length 60 mm [2.36"], (4 x) Part No. 12-0059
Length 120 mm [4.72"], (8 x) Part No. 12-0324
Length 240 mm [9.44"], (4 x) Part No. 12-0060

EXTENSION CHAINS



Makes it possible to align very large shafts.
Length: 900 mm [35.4"], (2 x) Part No. 12-0128



ADDITIONAL POWER SUPPLY



Chargeable battery pack which gives extra operating time. With or without built-in Bluetooth® unit. Part No. 12-0618 or 12-0617

CHARGER 12–36 V



To charge the display unit via 12–36 V socket, for example in a car. Part No. 12-0585

EXTENSION CABLES



Length 5 m [16.4'], Part No. 12-0108
Length 10 m [32.8'], Part No. 12-0180

PROTECTIVE COVER



Protective case for display unit. With shoulder strap. Part No. 01-1379

BARCODE READER



Barcode reader for registration of machine data. Connected in the USB port. Part No. 12-0619

VGA KIT



Makes it possible to show display unit screen image with a projector, for example in a training context. Must be factory installed on order. Part No. 12-0573

TARGET



Simplifies the rough alignment at very long distance and large alignment fault. Part No. 12-0588

SUN PROTECTION FOR PSD



To screen against extremely strong ambient light. Part No. 12-0587

LASER TRANSMITTER WITH SWEEP FUNCTION

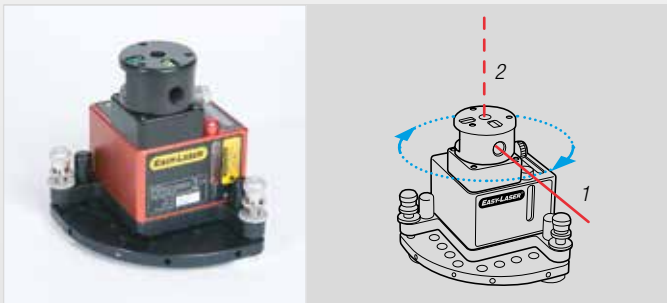

Laser transmitter D22 can be used to measure flatness, straightness, squareness and parallelism. The laser beam can sweep 360° (1) with a measurement distance of up to 40 metres [130'] in radius. The laser beam can be angled 90° to the sweep (2), within 0.01mm/m [0.5 mils/thou]. Part No. 12-0022.

BELT ALIGNMENT



E180 BTA. Laser transmitter and Bluetooth® wireless detector for belt transmission alignment. With built-in display. Use it as a separate tool or connect it to the E710 for extended functionality. Part No. 12-0796

VIBRATION MEASUREMENT



E285 Vibrometer probe. For measuring vibration and bearing condition. For connection to display unit, one of the red cables of system E710 is used. Part No. 12-0656

TECHNICAL DATA

System

Relative humidity	10–95%
Weight (complete system)	10 kg [22 lbs]
Carrying case	WxHxD: 500x400x200 mm [19.7"x15.7"x7.9"] Drop tested (3 m/10 feet). Dust and water proof.

Measuring units M / S

Type of detector	2-axis PSD 20x20 mm [0.78" sq]
Resolution	0.001 mm [0.05 mils]
Measuring errors	±1% +1 digit
Measurement range	Up to 20 m [66 feet]
Type of laser	Diode laser
Laser wavelength	635–670 nm
Laser class	Safety class II
Laser output	<1 mW
Electronic inclinometer	0,1° resolution
Thermal sensors	± 1° C accuracy
Environmental protection	IP class 66 and 67
Temperature range	-10–50 °C
Internal battery	Li Po
Housing material	Anodized aluminium
Dimensions	WxHxD: 60x60x42 mm [2.36"x2.36"x1.65"]
Weight	202 g [7.1 oz]

Display unit

Type of display/size	VGA 5.7" colour screen, backlit LED
Displayed resolution	0.001 mm / 0.05 thou
Power management	Endurio™ system for unbroken power supply
Internal battery (fixed)	Heavy duty Li Ion chargeable
Battery compartment	For 4 x R14 (C)
Operating time	Approx. 30 hours (at typical user cycle)
Temperature range	-10–50 °C
Connections	USB A, USB B, External, Easy-Laser® units, Network
Wireless communication	Class I Bluetooth® wireless technology
Internal memory	>100 000 measurements can be saved
Help functions	Calculator, Unit converter
Environmental protection	IP class 65
Housing material	PC/ABS + TPE
Dimensions	WxHxD: 250x175x63 mm [9.8"x6.9"x2.5"]
Weight (without batteries)	1080 g [2.4 lbs]

Bluetooth® wireless units

Wireless communication	Class I Bluetooth® wireless technology
Temperature range	-10–50 °C
Environmental protection	IP class 66 and 67
Housing material	ABS
Dimensions	53x32x24 mm [2.1"x1.2"x0.9"]
Weight	25 g [0.9 oz]

Cables

System cables	Length 2 m [78.7"], with Push/pull connectors.
USB cable	Length 1.8 m [70.8"]

Brackets etc.

Shaft brackets	Type: V-fixture for chain, width 18 mm [0.7"]. Shaft diameters: 20–450 mm [0.8"–17.7"] Material: anodised aluminium
Magnet bases	Holding strength: 800 N
Offset brackets	Displacement: 32 or 16 mm [1.2" or 0.6"]
Rods	Length: 120 mm, 60 mm [4.72", 2.36"] (extendable) Material: Stainless steel

EasyLink™ Data base software

System requirements	Windows® XP, Vista, 7, 8. For the export functions, Excel 2003 or newer must be installed on the PC.
---------------------	--

A complete system contains

1	Measuring unit M
1	Measuring unit S
1	Display unit
2	Bluetooth® units
2	Cables 2 m
2	Shaft brackets with chains
2	Extension chains
2	Magnet bases
2	Offset brackets
4	Rods 120 mm
4	Rods 60 mm
1	Manual
1	Quick reference manual
1	Measuring tape 3 m
1	USB memory with EasyLink™ PC software
1	USB cable
1	Charger (100–240 V AC)
1	Tool box
1	Shoulder strap for display unit
1	Optical cleaning cloth
1	CD with documentation
1	Carrying case

System Easy-Laser® E710 Shaft, Part No. 12-0440



Extend the warranty from 2 to 3 years by registering your system on the Internet.



Easy-Laser® is manufactured by Damalini AB, Alfagatan 6, SE-431 49 Mölndal, Sweden
Tel +46 (0)31 708 63 00, Fax +46 (0)31 708 63 50, e-mail: info@damalini.se, www.damalini.com
© 2014 Damalini AB. We reserve the right to make changes without prior notification.
Easy-Laser® is a registered trademark of Damalini AB.
Other trademarks belong to the relevant copyright holder.
This product complies with: EN60825-1, 21 CFR 1040.10 and 1040.11.
This device contains FCC ID: PVH0925, IC: 5325A-0925.



ISO9001
CERTIFIED

05-0476 Rev6



J.L. Griffin LLC.
4625-B Turtle Creek Drive,
Brookfield, WI 53005
TEL 414.218.8088
E-mail jlm@jgriffin.com